

**Purpose:**

The primary purpose of the Presidential Administrative Communicator (PAC) is to act as a gateway to the field infrastructure to allow your VOTE to request information about the state of the campaign and to woo the voters at a polling station to your candidate.

**Interface Connection**

**Connector:**

The connector of the PAC is a 6-pin keyed Molex connector.

**Pinout:**

Pin	Name/Function
1	+3.3V (@ 100mA) / Power to the PAC ( $V_{dd}$ )
2	SDI / Serial Data Into the PAC
3	SDO / Serial Data Out of the PAC
4	SCK / Serial Clock
5	SS / active low select line for the PAC with on-board pull-up to +3.3V
6	GND / Ground reference for the PAC



**Electrical Specifications**

Parameter	Min.	Max	Units
$V_{iH}$	$V_{dd} * 0.65$		V
$V_{oH}$	$V_{dd} - 0.4$		V
$V_{iL}$		$V_{dd} * 0.35$	V
$V_{oL}$		0.4	V
$I_{iH}, I_{iL}$		$\pm 1$	$\mu A$
$I_{oH}$	-20		$\mu A$
$I_{oL}$	20		$\mu A$
All Specifications at $V_{dd} = 3.3V$			

**Byte Transfer Specification**

The Presidential Administrative Communicator uses a synchronous serial signaling method to transfer data into and out of the PAC. The signaling method is compatible with SPI communications, with the PAC operating as a slave device on an SPI network. The  $\overline{SS}$  line must be lowered (asserted) to begin an 5-byte (40 bit) transfer and raised at the completion of the 5-byte transfer. The  $\overline{SS}$  line must remain de-asserted for a minimum of 2ms between transfers. The SDO line represents the serial data out of the PAC, while the SDI line represents serial data into the PAC.

The relationships between the four lines involved in the transfer of a byte are shown in the figure & table below:

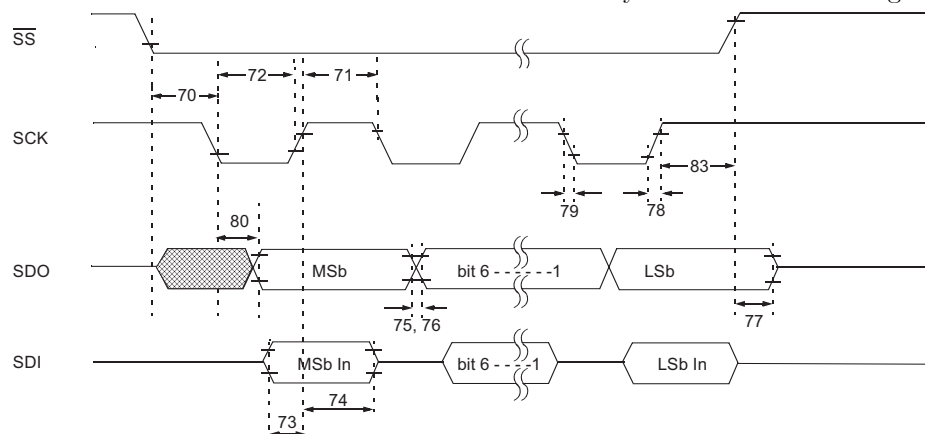

Param No.	Symbol	Characteristic	Min	Typ	Max	Units	Conditions
70*	TssL2sCH, TssL2sCL	$\overline{SS} \downarrow$ to SCK $\downarrow$ or SCK $\uparrow$ input	Tcy <sup>a</sup>	—	—	ns	
71*	Tsch	SCK input high time (Slave mode)	Tcy + 20	—	—	ns	
72*	TscL	SCK input low time (Slave mode)	Tcy + 20	—	—	ns	
73*	TdIV2scH, TdIV2scL	Setup time of SDI data input to SCK edge	100	—	—	ns	
74*	Tsch2dIL, TscL2dIL	Hold time of SDI data input to SCK edge	100	—	—	ns	
75*	TdoR	SDO data output rise time	3.0-5.5V	—	10	25	ns
			2.0-5.5V	—	25	50	ns
76*	TdoF	SDO data output fall time	—	10	25	ns	
77*	TssH2doZ	$\overline{SS} \uparrow$ to SDO output high-impedance	10	—	50	ns	
78*	TscR	SCK output rise time (Master mode)	3.0-5.5V	—	10	25	ns
			2.0-5.5V	—	25	50	ns
79*	TscF	SCK output fall time (Master mode)	—	10	25	ns	
80*	Tsch2doV, TscL2doV	SDO data output valid after SCK edge	3.0-5.5V	—	—	50	ns
			2.0-5.5V	—	—	145	ns
83*	Tsch2ssH, TscL2ssH	$\overline{SS} \uparrow$ after SCK edge	1.5Tcy + 40	—	—	ns	

\* These parameters are characterized but not tested. <sup>a</sup>Tcy = 33µS

## Byte Level Protocol Specification

### Common Byte Format:

Exchanges between the Presidential Administrative Communicator (PAC) and your VOTE take place with five successive bytes being exchanged. The first byte from the VOTE to the PAC is the actual command. The value returned from the PAC during this transfer will be 0x00, but has no meaning. The values sent to the PAC as the second through fifth bytes of the sequence should always be 0x00. The meanings of the values returned by the second through fifth byte transfers will be the results from the command byte.

### VOTE to Presidential Administrative Communicator Bytes:

The meaningful values for the command bytes from the VOTE to the Presidential Administrative Communicator are shown in the following table:

Command	Meaning
0b1100 0000	Return the <b>Status</b> of the campaign.
0b10MR iiii	<b>Request</b> a change in polling station state.
0b0111 0000	<b>Query</b> for new response ready.

In the above message, M = My Color, R = requested Color (for both, 0=RED, 1=BLUE), iiii = 4bit number identifying the current frequency measured at the polling station (See **Codes for Frequency of the Magnetic Field at a Polling Station**, below). Making a **Request** to change a polling station's state may take significant time (up to hundreds of ms) to complete.

### Presidential Administrative Communicator to VOTE Bytes:

The values and meanings of the response bytes returned by the Presidential Administrative Communicator are shown in the following table:

Command	Response Bytes	Description of meaning
0b1100 0000 (0xC0)	0xFF, SS1, SS2, SS3	SS1 = Station Status Byte 1, SS2 = Station Status Byte 2, SS3 = Station Status Byte 3
0b10MR iiii	0xFF, 0x00, 0x00, 0x00	The <b>Request</b> to change a polling station's state takes time to complete. After issuing this Request, you <b>must</b> issue repeated <b>Query</b> commands until the PAC returns a Response Ready status. Allow at least 200ms between successive REQUESTs. Subsequent requests, without an intervening successful <b>Query</b> response will be ignored and not result in further Requests being forwarded to the SuperPAC.
0b0111 0000	0xFF, RR, RS, 0x00	RR = Response Ready Byte, RS = Request Status Byte

**Station Status Byte 1**

7	6	5	4	3	2	1	0
PS11	PS10	PS21	PS20	PS31	PS30	PS41	PS40

Field Name	Description
Polling Station #1 Status (PS11, PS10)	0,0 = Unclaimed 0,1 = BLUE 1,0 = RED 1,1 = undefined, not used
Polling Station #2 Status (PS21, PS20)	0,0 = Unclaimed 0,1 = BLUE 1,0 = RED 1,1 = undefined, not used
Polling Station #3 Status (PS31, PS30)	0,0 = Unclaimed 0,1 = BLUE 1,0 = RED 1,1 = undefined, not used
Polling Station #4 Status (PS41, PS40)	0,0 = Unclaimed 0,1 = BLUE 1,0 = RED 1,1 = undefined, not used

**Station Status Byte 2**

7	6	5	4	3	2	1	0
PS51	PS50	PS61	PS60	PS71	PS70	PS81	PS80

Field Name	Description
Polling Station #5 Status (PS51, PS50)	0,0 = Unclaimed 0,1 = BLUE 1,0 = RED 1,1 = undefined, not used
Polling Station #6 Status (PS61, PS60)	0,0 = Unclaimed 0,1 = BLUE 1,0 = RED 1,1 = undefined, not used
Polling Station #7 Status (PS71, PS70)	0,0 = Unclaimed 0,1 = BLUE 1,0 = RED 1,1 = undefined, not used
Polling Station #8 Status (PS81, PS80)	0,0 = Unclaimed 0,1 = BLUE 1,0 = RED 1,1 = undefined, not used

**Station Status Byte 3**

7	6	5	4	3	2	1	0
PS91	PS90	0	0	0	ASR	ASB	GS

Field Name	Description
Polling Station #9 Status (PS91, PS90)	0,0 = Unclaimed                      01 = BLUE 1,0 = RED                                11 = undefined, not used
Attack Ad Status for RED (ASR)	1 = Under Attack
Attack Ad Status for BLUE (ASB)	1 = Under Attack
Game Status (GS)	0 = Waiting 1 = Campaigning

**Response Ready Byte**

7	6	5	4	3	2	1	0
Response Ready Status							

Field Name	Description
Response Ready Status	0x00 = Response not ready 0xAA = Response ready Response Ready only returned once per <b>Request</b> If a response is not ready, then the Request Status Byte will be 0x00

**Request Status Byte**

7	6	5	4	3	2	1	0
ACK1	ACK0	RBN1	RBN0	LOC3	LOC2	LOC1	LOC0

Field Name	Description
Acknowledge (ACK1, ACK0)	0,0 = NACK 0,1 = ACK 1,0 = Blocked 1,1 = Busy
Red/Blue/None (RBN1, RBN0)	0,0 = Unclaimed 0,1 = BLUE 1,0 = RED 1,1 = undefined, not used
Location (LOC3-LOC0)	4-bit number indicating the location of the polling station. For the number to location correspondence, see Codes for Locations of the Polling Stations, below.

In response to a **Request** for a change in the polling station state, a reply of

ACK	Will only occur in response to a <b>Request</b> if the reported frequency is currently active at a polling station <b>and</b> that station is not currently in a state change transaction <b>and</b> the requestor is not currently under attack.
NACK	Will occur in response to a <b>Request</b> if the reported frequency is not currently active at a polling station. In this case, the R/B/N status will be 1,1 and the location bits will be 0000
Busy	Will occur if the requested polling station is currently in a transaction.
Blocked	Will occur if the requesting VOTE is currently under the influence of an Attack Ad.

**Query the Status of the Game:**

To query the game status, send a byte of 0xC0 to the PAC followed by 4 bytes of 0x00. The PAC will process the query and during the four 0x00 bytes of the exchange will return 0xFF, followed by the three status bytes as described above.

**Changing the state of a Polling Station:**

To successfully change the state of a polling station a VOTE must prove that they actually occupy that polling station. That proof is demonstrated by successfully executing two correctly formatted **Request** commands with no intervening unsuccessful **Request** commands. After the first **Request**, the SuperPAC will mark the polling station as being in a transaction sequence and change the frequency of the requested polling station, but not its RED/BLUE state. To complete the state change, the VOTE must issue a second **Request** with the new frequency. After this, second, successful request, the SuperPAC will change the state of the polling station and close transaction sequence, making the polling station available for a later state change request.

**Codes for Frequency of the Magnetic Field at a Polling Station :**

Code	0000	0001	0010	0011	0100	0101	0110	0111
Period (μs)	1333	1277	1222	1166	1111	1055	1000	944
Code	1000	1001	1010	1011	1100	1101	1110	1111
Period (μs)	889	833	778	722	667	611	556	500

**Codes for Locations of the Polling Stations :**

Code	0001	0010	0011
Location	Sacramento	Seattle	Billings
Code	0100	0101	0110
Location	Denver	Dallas	Chicago
Code	0111	1000	1001
Location	Miami	Washington, DC	Concord

**Power on and reset behavior:**

Initially, after power on or a reset, the Presidential Administrative Communicator will return 0xFF from any query until such time as the Presidential Administrative Communicator is internally initialized.

**Command Timing:**

The interval between two successive transfers from VOTE to Presidential Administrative Communicator should be at least 2ms. The SS line must remain high for a minimum of 2ms between successive transfers.

**Invalid Command Bytes:**

If the Presidential Administrative Communicator receives a command byte not listed in the table, it will respond to the invalid command byte by queuing a series of 0xFF bytes to be returned to the VOTE.

**Sample Byte Sequences:**

In the communication sequence diagrams shown below, there are 3 columns. The left column represent your VOTE. The Middle column represents the PAC and the right column represents the SuperPAC. The Diagrams are read top to bottom to follow a conversation between the VOTE and the PAC and between the PAC and the SuperPAC.

VOTE		PAC		SuperPAC
Normal Capture				
Measures freq. at polling station				
<b>Request</b> w/ Valid Freq.	→ ←	Returns Request response to VOTE, asks SuperPAC to change the state of the polling station	→	Check Freq, Check Attack status, Check transaction status if all OK, then Starts Transaction, changes freq of polling station
<b>Query</b>	→ ←	Returns Response Not Ready (may be repeated 0 or more times until the SuperPAC replies)		
			←	Replies that new freq is in place
<b>Query</b>	→ ←	Returns Response Ready, ACK		
Measures new Freq.				
<b>Request</b> w/ Valid Freq.	→ ←	Returns Request response to VOTE, asks SuperPAC to change the state of the polling station	→	Closes transactions, changes state of polling station
<b>Query</b>	→ ←	Returns Response Not Ready (may be repeated 0 or more times until the SuperPAC replies)		

			←	Replies that state has been changed.
<b>Query</b>	→ ←	Returns Response Ready, ACK		
<b>Bad Frequency</b>				
<b>Request w/ InValid Freq.</b>	→ ←	Returns Request response to VOTE	→	Check Frequency against list of active frequencies
<b>Query</b>	→ ←	Returns Response Not Ready (may be repeated 0 or more times until the SuperPAC replies)		
			←	Replies that frequency is invalid
<b>Query</b>	→ ←	Returns NACK		
<b>Game Status Request</b>				
<b>Status request</b>	→ ←	Returns Campaign status		
<b>While under attack</b>				
Measures freq. at polling station				Check Freq, Check Attack status, Check transaction status
<b>Request w/ Valid Freq.</b>	→ ←	Returns Request response to VOTE, asks SuperPAC to change the state of the polling station	→	
<b>Query</b>	→ ←	Returns Response Not Ready (may be repeated 0 or more times until the SuperPAC replies)		
			←	Replies that VOTE is under attack
<b>Query</b>	→ ←	Returns Response Ready, Blocked		
<b>If station is amid a capture</b>				
Measures freq. at polling station				
<b>Request w/ Valid Freq.</b>	→ ←	Returns Request response to VOTE, asks SuperPAC to change the state of the polling station	→	Check Freq, Check Attack status, Check transaction status
<b>Query</b>	→ ←	Returns Response Not Ready (may be repeated 0 or more times until the SuperPAC replies)		
			←	Replies that station is in a transaction
<b>Query</b>	→ ←	Returns Response Ready, Busy		

## Physical Specifications

### Dimensions:

The Presidential Administrative Communicator dimensions are 2" x 3" x 1".

### Revision History:

Rev 3: Updated language and timing describing REQUEST command. Updated frequencies of polling stations to avoid wire detection interference.

Rev 2: Updated polling station numbering, corrected number of bytes in SPI transfer.

Rev 1: First Published revision.